

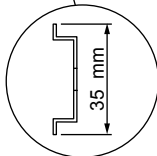

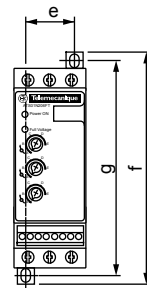

# Altistart

## ATS 01N2••LU/QN/RT

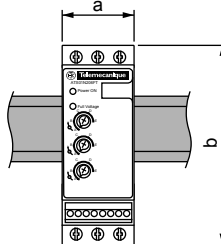
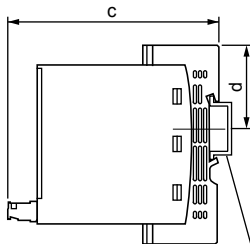
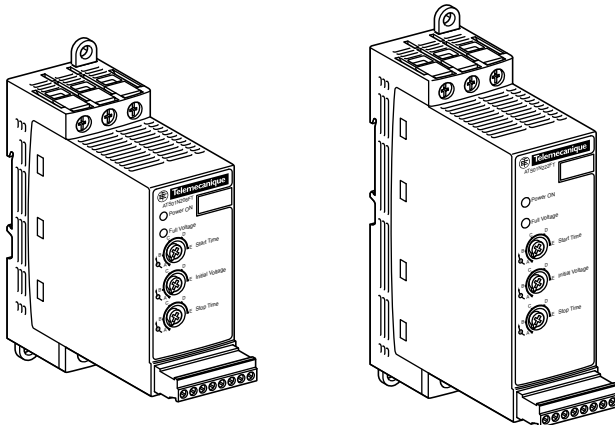

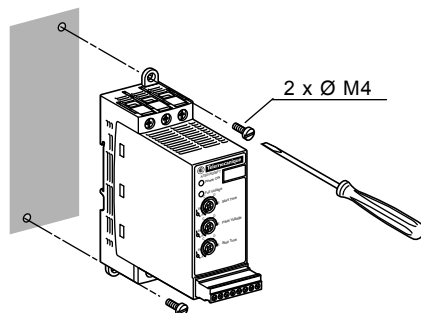
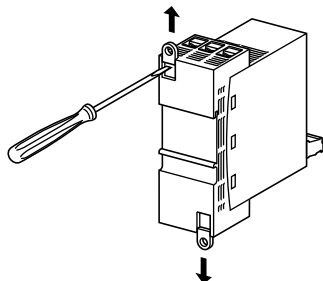
	a mm	b mm	c mm	d mm	e mm	f mm	g mm
ATS 01N206••							
ATS 01N209••	45	124	131	53	30	145	132
ATS 01N212••							
ATS 01N222••	45	154	131	72	30	175	162
ATS 01N232••							



				
	[ mm <sup>2</sup> ]	AWG	Nm	lb/in
1/L1, 2/T1, 3/L2, 4/T2, 5/L3, 6/T3	10	8	1,9...2,5	17...22
R1A, R1C, COM, LI+, LI1, LI2, LO1, BOOST	2,5	14	0,5	4,5

	UL  CLASS J
<b>ATS 01N206**</b>	<b>20 A</b>
<b>ATS 01N209**</b>	<b>30 A</b>
<b>ATS 01N212**</b>	<b>35 A</b>
<b>ATS 01N222**</b>	<b>80 A</b>
<b>ATS 01N232**</b>	<b>100 A</b>

	U1	
<b>ATS 01N2**LU</b>	200 - 240 V	50 / 60 Hz
<b>ATS 01N2**QN</b>	380 - 415 V	50 / 60 Hz
<b>ATS 01N2**RT</b>	440 - 480 V	50 / 60 Hz

**⚠ DANGER**  
**HAZARDOUS VOLTAGE**  
 Disconnect all power before servicing.  
**Electric shock will result in death or serious injury.**

**⚠ PELIGRO**  
**TENSION PELIGROSA**  
 Desconecte todas las alimentaciones antes de efectuar el servicio.  
**Una descarga eléctrica podrá causar la muerte o lesiones serias.**

**⚠ DANGER**  
**TENSION DANGEREUSE**  
 Coupez toutes les alimentations avant l'entretien.  
**L'électrocution entrainera la mort ou des blessures graves.**

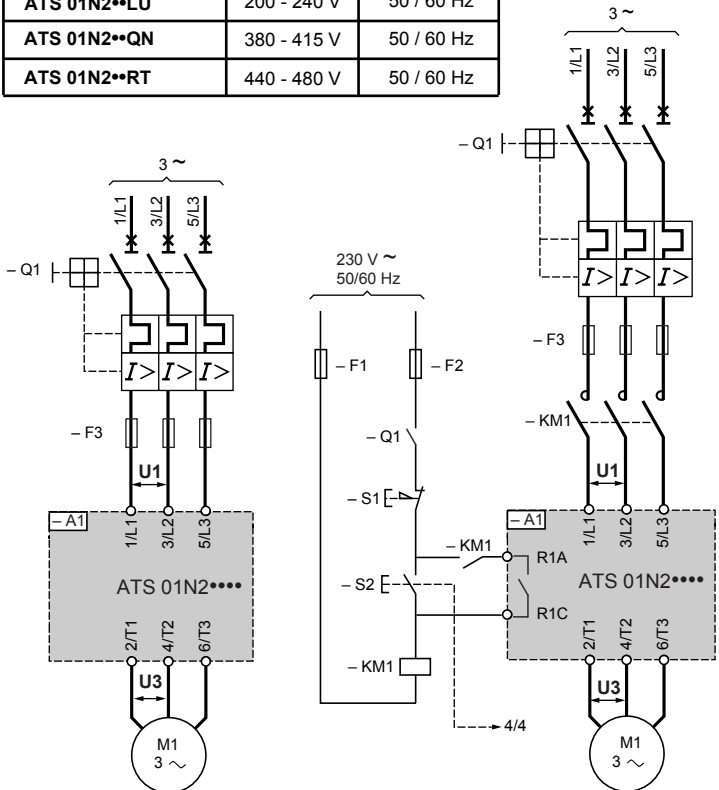

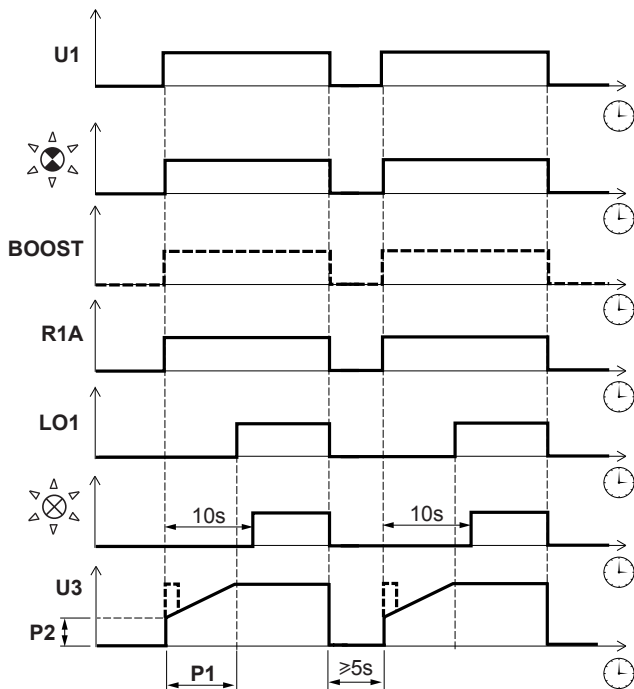
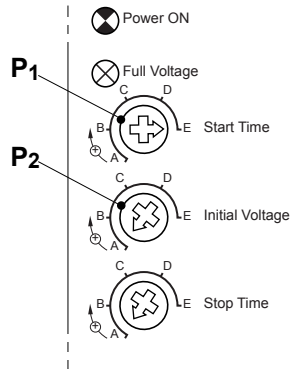
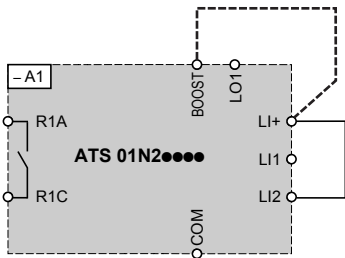

Power ON

